

PRO-Series







Multi Module CW Fiber Lasers

MFMC-6000 to 20000

Maxphotonics PRO-Series is the flagship of our current CW lasers offering integrated with our most advanced technology and our 18 years experience in laser cutting and welding. PRO-Series targets the most demanding markets, where top performance is needed. At the same time offering performance level D (PL-d) safety standard and various options for control interface to minimize our customer's switching cost.



Product Features

-  Top-shelf quality and performance
-  Multiple control interfaces – easy to be integrated
-  Performance Level D (PL-d) safety standard
-  ZERO power degrading for up to 3 years to protect your investment and productivity
-  Apply to major EU/US standards/certificates including CE, ETL, FDA. UL compatible
-  Lowest technical/engineering switching cost from your current laser source

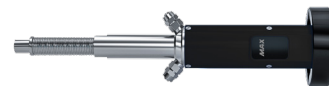

Our new generation LOE fiber connector guarantees the best connection robustness and dust isolation. Greatly improved cooling performance and power stability during high reflective material processing

*Compatible with mainstream cutting heads

**Conventional QBH option also provided

MFMC-6000 to 20000 Fiber Laser Specifications

Models	MFMC-6000	MFMC-12000	MFMC-15000	MFMC-20000
OPTICAL SPECIFICATIONS				
Nominal Power	6 kW	12 kW	15 kW	20 kW
Mode of Operation	CW / Modulated			
Polarization	Random			
Power Redundancy	> 10 %			
Power Tunability	10 to 100 %			
Wavelength	1080 ± 5 nm			
Power Stability	± 2 %			
Laser Beam Quality, BPP	3.5 to 4.5 mm x mrad (@100µm Fiber Core)			
	5 to 6.5 mm x mrad (@150µm Fiber Core)			
	8 to 10 mm x mrad (@200µm Fiber Core)			
Modulation Frequency	≤ 5 KHz			
Preview Red Light Power	200 µW			
FIBER DELIVERY SYSTEM				
Interface	QBH	LOE		
Length	20 m standard, other lengths optional			
Fiber Core Diameter	100 (150 / 200) µm			
Bending Radius	min. 200 mm			
ELECTRICAL RATINGS				
Bus Control System	EtherCAT / Profinet / Profibus			
Safety Function	EN ISO 13849-1 / Performance Level D (PL-d)			
Supply Voltage	280-500 VAC 3-phase 50 / 60Hz			
OTHER SPECIFICATIONS				
Power Cable	14 m			
Signal cable	14 m			
Operating Temperature	+10 to +40 °C			
Storage Temperature	-10 to +60 °C			
Humidity	10 to 85%			
Cooling Method	Water Cooling			
Cooling Medium	Distilled water/ Glycol Antifreeze			
Dimension	1050 x 1123 x 1250 mm ³			
Weight	527 (±8) kg	632 (±5) kg	728 (±10) kg	815 (±10) kg

Mechanical Specifications (mm)

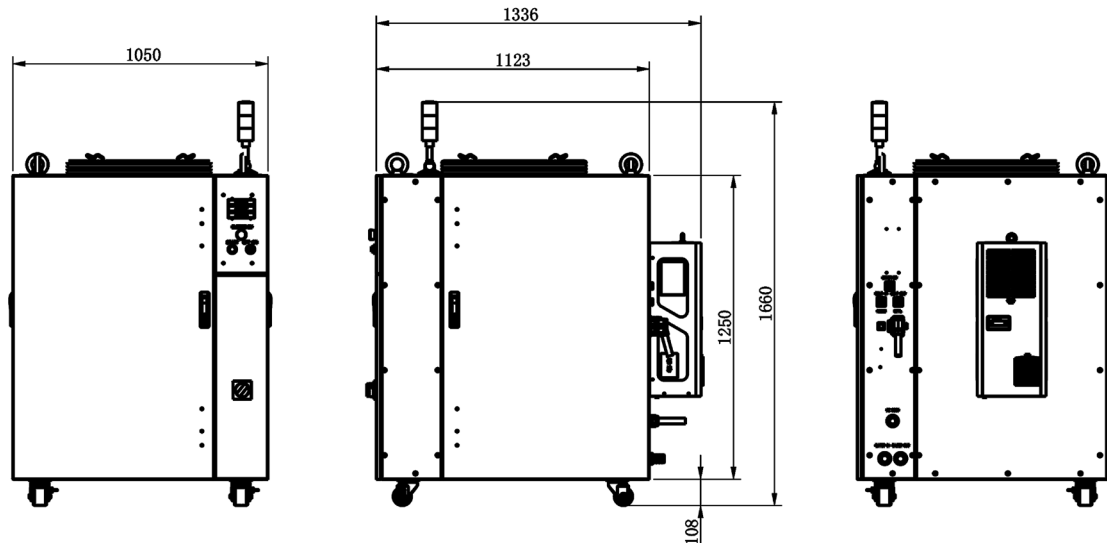

Maxphotonics Co., Ltd.

Address: Maxphotonics Industrial Park, 3rd Furong Road,
Furong Industrial Area, Shajing, Bao'an, Shenzhen, China.518125
E-Mail: sales@maxphotonics.com <http://en.maxphotonics.com>

MAX PHOTONICS